

SAFEMASTER Delay module, Release Delay BA 7924, IL 7824, IN 7824



0221 ES7



BA 7924.21



BA 7924.21/002



IL 7824.21



IN 7824.21

- According to
 - Performance Level (PL) c and category 2 to EN ISO 13849-1: 2008
 - SIL Claimed Level (SIL CL) 2 to IEC/EN 62061
 - Safety Integrity Level (SIL) 2 to IEC/EN 61508
 - Category 2 to EN 954-1
- BA 7924.21/002 und BA 7924.21/003
 - Performance Level (PL) d and category 3 to EN ISO 13849-1: 2008
 - SIL Claimed Level (SIL CL) 2 nach IEC/EN 62061
 - Safety Integrity Level (SIL) 2 to IEC/EN 61508
 - Category 3 to EN 954-1
- Release delay
- Without auxiliary voltage
- Output: 1 NC, 1 NO contacts, forcibly guided
- Operating state display
- Optionally with adjustable or fixed time delay up to 30 s
- Optionally with redundant timing circuit
- Optionally with 1 or 2 separate timing circuits
- Optionally also in housing for distribution board
- Width 45 mm, 35 mm or 52.5 mm

Approvals and marking



* see variants

Application

Delayed switch-off in safety-oriented controls.

ATTENTION!



To achieve the safety levels stated under features of BA 7924.21/002 and BA 7924.21/003, a suitable supervising control must check the NC contact 15/16 before starting to make sure that both relays (K1 and K2) are switched off.

Indication

LED's comes on when A1 / A2 connected to supply

Notes

The output contacts of the two timing circuits are connected in series in the BA 7924.21/002 and /003 modules. This results in so-called switch-off redundancy, i.e. the contact path 27-28 is opened reliably after expiry of the predefined delay time, even if a contact in this path is welded.

Function diagram

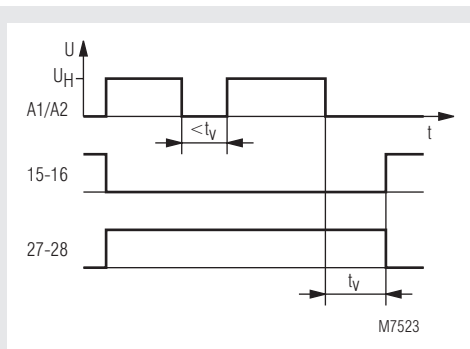

M7523

Circuit diagrams

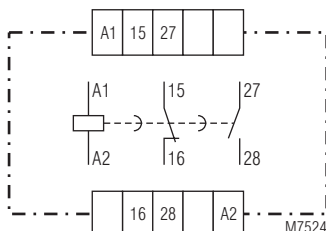

BA 7924.21
BA 7924.21/100

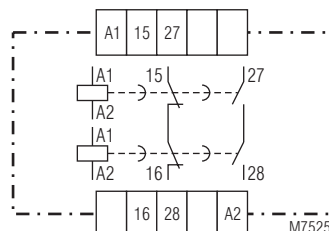

BA 7924.21/002
BA 7924.21/003

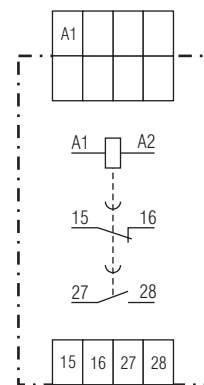

IL 7824.21

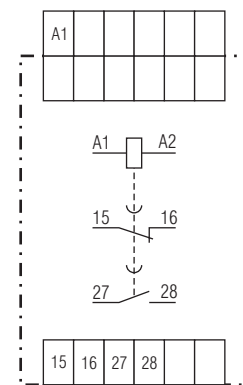

IN 7824.21

M7526_a

M7527_a

Technical Data

Time delay t_v

BA 7924.21:	0.1 ... 1 s; 0.3 ... 3 s; 0.5 ... 5 s; 1 ... 10 s; 3 ... 30 s
BA 7924.21/001:	1 s; 3 s; 5 s; 10 s; 30 s fixed
BA 7924.21/002:	5 s; 10 s fixed
BA 7924.21/003:	0.5 ... 5 s; 1 ... 10 s
IL 7824.21:	0.1 ... 1 s; 0.3 ... 3 s
IL 7824.21/100:	0.5 s; 1 s; 3 s fixed
IN 7824.21:	0.5 ... 5 s; 1 ... 10 s
IN 7824.21/100:	5 s; 10 s fixed
Repeat accuracy:	±15 % of set value
Minimum closing time:	50 % of full scale value

Input

Nominal voltage U_N:	DC 24 V AC 230 V (only BA 7924.21 and BA 7924.21/001)
Voltage range:	AC 0.8 ... 1.1 U_N
at 10 % residual ripple:	DC 0.9 ... 1.2 U_N
at 48 % residual ripple:	DC 0.8 ... 1.1 U_N
Nominal consumption:	0.85 W / 4.5 VA
at BA 7924.21/002 and BA 7924.21/003:	1.7 W
Nominal frequency:	50 / 60 Hz

Output

Contacts

BA 7924.21:	1 NC, 1 NO contacts
IL/IN 7824.21:	1 NC, 1 NO contacts
Contact type:	Relay, forcibly guided
Release delay typ. bei U_N:	10 ms + t_v
Nominal output voltage:	AC 10 ... 250 V, DC 10 ... 110 V
Thermal current I_{th}:	max. 8 A
Switching capacity	
to AC 15	
for NO contact:	3 A / AC 230 V IEC/EN 60 947-5-1
for NC contact	1 A / AC 230 V IEC/EN 60 947-5-1
to AC 13	
for NO contact:	2 A / DC 24 V IEC/EN 60 947-5-1
for NC contact	2 A / DC 24 V IEC/EN 60 947-5-1
Electrical life	IEC/EN 60 947-5-1
to AC 15 at 1 A, AC 230 V:	≥ 2.5 x 10 ⁵ switching cycles
Permissible operating frequency:	max. 2000 switching cycles / h but please note minimum closing time
Short circuit strength	
max. fuse rating:	6 A g LIEC/EN 60 947-5-1
Mechanical life:	10 x 10 ⁶ switching cycles

General Data

Operating mode:	Continuous operation
Temperature range:	- 20 ... + 60 °C
Clearance and creepage distances	
rated impuls voltage / pollution degree:	4 kV / 2 IEC 60 664-1
EMC	
Electrostatic discharge:	8 kV (air) IEC/EN 61 000-4-2
HF irradiation:	10 V / m IEC/EN 61 000-4-3
Fast transients:	4 kV IEC/EN 61 000-4-4
Interference suppression:	Limit value class B EN 55011
Degree of protection	
Housing:	IP 40 IEC/EN 60 529
Terminal plate:	IP 20 IEC/EN 60 529
Housing:	Thermoplastic with V0 behaviour according to UL subject 94
Vibration resistance:	Amplitude 0.35 mm, IEC/EN 60 068-2-6 frequency 10 ... 55 Hz
Climate resistance:	20 / 060 / 04 IEC/EN 60 068-1
Terminal arrangement	
at BA 7924:	DIN 46199-5
Terminal designation:	EN 50 005
Wire connection:	max. 2 x 2.5 mm ² solid or max. 2 x 1.5 mm ² stranded ferruled DIN 46 228-1/-2/-3/-4
Wire fixing:	Flat terminals with self-lifting clamping piece IEC/EN 60 999-1 DIN rail IEC/EN 60 715
Mounting:	
Weight:	
BA 7924 DC / AC:	200 g / 350 g
IL 7824 / IN 7824:	120 g / 150 g

Technical Data

Dimensions

Width x height x depth

BA 7924:	45 x 74 x 133 mm
IL 7824:	35 x 89 x 58 mm
IN 7824:	52.5 x 89 x 58 mm

Safety related data BA 7924.21 and /001

Values according to EN ISO 13849-1:

Category:	2	
PL:	c	
MTTF ^d :	574.4	a (year)
DC _{avg} :	78.8	%
d _{op} :	365	d/a (days/year)
h _{op} :	24	h/d (hours/day)
t _{cycle} :	3600	s/cycle
	≅ 1	/h (hour)

Values according to IEC/EN 62061 / IEC/EN 61508:

SIL CL:	2	IEC/EN 62061
SIL	2	IEC/EN 61508
HFT:	0	
DC _{avg} :	78.8	%
SFF:	93.4	%
PFH _D :	4.21E-08	h ⁻¹
T ₁ :	20	a (year)

Safety related data BA 7924.21/002 and /003

Values according to EN ISO 13849-1:

Category:	3	
PL:	d	
MTTF ^d :	582.1	a
DC _{avg} :	79.9	%
d _{op} :	365	d/a (days/year)
h _{op} :	24	h/d (hours/day)
t _{cycle} :	3600	s/cycle
	≅ 1	/h (hour)

Values according to IEC/EN 62061 / IEC/EN 61508:

SIL CL:	2	IEC/EN 62061
SIL	2	IEC/EN 61508
HFT:	1	
DC _{avg} :	79.9	%
SFF:	93.4	%
PFH _D :	2.63E-09	h ⁻¹
T ₁ :	20	a (year)

*) HFT = *) HFT = Hardware-Failure Tolerance



The values stated above are valid for the standard type and for the variants BA7924.21/002 and BA7924.21/003. Safety data for other variants are available on request.

The safety relevant data of the complete system has to be determined by the manufacturer of the system.

CCC-Data

Nominal voltage U_N :

BA 7924:	DC 24 V, AC 230V
----------	------------------

Thermal current I_{th} :

max. 5 A

Switching capacity

to AC 15		
NO contact:	2 A / AC 230 V	IEC/EN 60 947-5-1
to DC 13		
NO contact:	1 A / DC 24 V	IEC/EN 60 947-5-1
NC contact:	1 A / DC 24 V	IEC/EN 60 947-5-1



Technical data that is not stated in the CCC-Data, can be found in the technical data section.

Standard type

BA 7924.21 DC 24 V 0.3 ... 3 s
 Article number: 0039707 stock item
 • Output: 1 NO contact
 1 NC contact
 • Nominal voltage U_N : DC 24 V
 • Time range: 0.3 ... 3 s
 • Width: 45 mm

Variants

BA 7924.21/61: with UL approval (Canada/USA)
 BA 7924.21: 1 timing circuit, adjustable time
 BA 7924.21/001: 1 timing circuit, fixed time
 BA 7924.21/002: 2 timing circuit, fixed time
 BA 7924.21/003: 2 timing circuit, adjustable time
 Delay modules in housing for distribution board:
 IL 7824.21: 1 timing circuit, adjustable time delay, 35 mm wide
 IN 7824.21: 1 timing circuit, adjustable time delay, 55 mm wide
 IL 7824.21/100: 1 timing circuit, fixed time delay, 35 mm wide
 IN 7824.21/100: 1 timing circuit, fixed time delay, 55 mm wide

Ordering example for variants

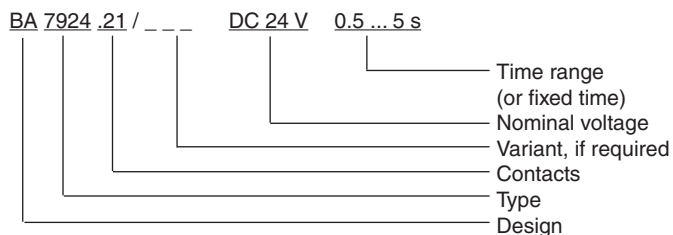

Application example

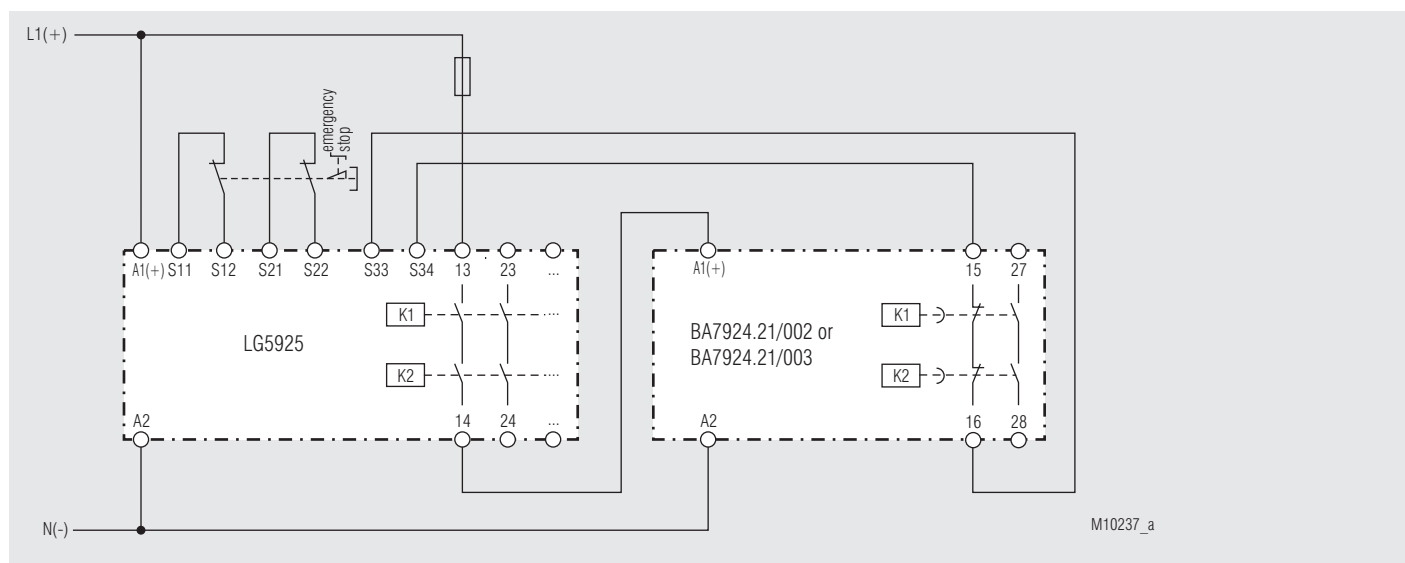

LG 5925 with BA 7924.21/002 e.g. BA 7924.21/003, suitable up to SIL 3, Performance Level e; Cat. 3

